

Box Fan Agricultural HV125 Series



■ Features

The Hi-volume Belt Drive fan unit is specifically designed to ventilate larger buildings, by moving substantial amounts of air at low pressure with minimal energy consumption.

Available in two sizes, 1000mm and 1250mm diameter, each with single or three phase motors and the option of louvres and guards.

■ Construction

Constructed from galvanised steel with a specially designed stainless steel propeller, these fans are extremely hard wearing and robust in application. The drive mechanism comprises of a sealed for life maintenance free ball bearings, which means low noise and vibration levels. Units are supplied fully assembled complete with a standard safety guard on suction side and counter balanced air operated louvre shutter on outlet.

■ Motors

The motors are to be foot mounted totally enclosed metric type to Ip55, with sealed for life bearings and class F insulation, suitable for operating temperatures up to 50°C. Motors are constructed with finned aluminium casing to provide excellent heat dissipation resulting in a flexible and durable motor.

■ Impellers

Propeller blades are fixed pitch. The six blades are attached to a mild steel powder coated hub. The complete assembled propeller unit is balanced to grade G6.3.



Factory



Agricultural

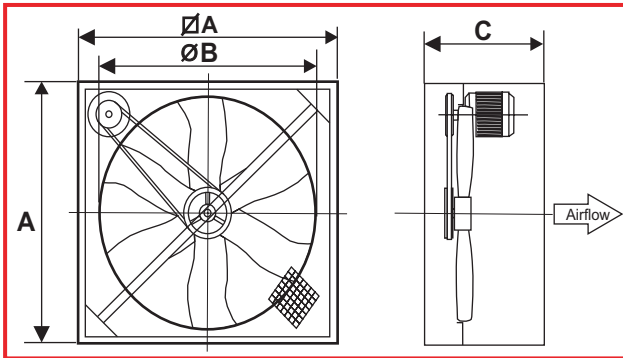

■ Dimensions(mm)

Model	ØA	ØB	C	Descriptions
HV100L	1060	938	400	Louvre
HV125	1380	1250	440	Guards only
HV125L	1380	1250	440	Louvre

■ Technical data

Model	V	KW	A	Hz	r.p.m.	m ³ /h	dB	Kg
HV100L	380	0.5	1.5	50	450	32000	76	53
HV125	380	1.1	2.75	50	450	44500	78	88
HV125L	380	1.1	2.75	50	450	44500	78	88